

10MSP VERTICAL PERSONNEL LIFTS

Platform

- 0.69 m x 0.50 m (W x L) Operator platform self closing saloon style gates
- 0.66 m x 0.66 m (W x L) Adjustable height material tray
- Carry deck on chassis
- Safety interlocked controls
- Point & Go[®] fully proportional drive/steer single joystick control
- Joystick enable for lift and drive
- Variable speed elevation control
- Lanyard attachment anchor

Power & Transmission

- 4 x Sealed 6V, 210 A/Hr maintenance-free AGM batteries
- Automatic 5 hour battery charger
- On-board diagnostics
- Automatic power-off battery saver control
- Battery discharge indicator (located on platform and base)
- Direct electric two wheel drive
- Heavy duty planetary gear hubs
- Non mark tyres and casters
- Brake release
- Non-marking tyres

Functional Equipment & Accessories

- Low maintenance anodised aluminium mast
- Pothole Protection System (PHP)
- Manual Descent
- Tilt light and alarm
- Key lock main power switch
- Hour meter
- Transportation tie-down lugs
- Fork truck pockets
- Horn
- Amber strobe light

Available Options

- Programmable 4 digit security lock
- Travel alarm
- Guide roller system



10MSP VERTICAL PERSONNEL LIFTS

Working Height	5.05 m
Platform Height	3.05 m
Operator Platform Capacity	160 kg
Material Tray Capacity	115 kg
Carry Deck Capacity	115 kg
Platform Size (W x L) - swing gates entry	0.69 m x 0.50 m
Material Tray Size (W x L)	0.66 m x 0.66 m
Overall Height – Stowed	1.45 m
Overall Width – Stowed ²	0.83 m
Overall Length	1.56 m
Ground Entry Height	0.35 m
Minimum Tray Stowed Height	0.86 m
Maximum Tray Stowed Height	1.32 m
Maximum Tray Elevated Height	4.04 m
Drive Speed – Lowered	5.4 km/h
Drive Speed – Elevated	0.8 km/h
Distance from Platform to Wall – Over Front	0.00 m
Distance from Platform to Wall – Over Sides	0.00 m
Machine weight ¹	555 kg
Maximum Ground Bearing Pressure Front Casters	11.70 kg/cm ²
Maximum Ground Bearing Pressure Rear Wheels	6.70 kg/cm ²
Turning Radius	Zero
Gradeability	15%
Wheel Diameter – Drive Wheel	0.32 m
Wheel Diameter – Front Castors	0.20 m
Battery	Maintenance-Free 210 A/hr AGM (x 4)
Battery Charger	25 Amp Automatic
Drive System	Direct Electric

¹ Certain options or country standards may increase weight and/or dimensions.

² Without rubber bumpers Width: 0.75 m .

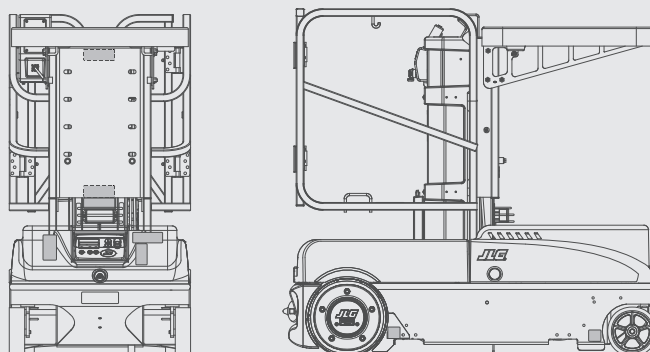

JLG Industries, Inc. is a leading designer and manufacturer of access equipment and complementary services and attachments.

JLG has manufacturing facilities in the United States, France, Romania, China and Belgium. Customers throughout Europe, Scandinavia, Africa and the Middle East benefit from a network of dedicated sales and service operations designed to deliver the highest levels of support.

JLG is an Oshkosh Corporation company.

www.jlgeurope.com

JLG is continually researching and developing products and reserves the right to make modifications without prior notice. All data in this document is indicative. Certain options or country standards will increase weight. Specifications may change to meet country standards or with the addition of optional equipment.